

# Technical data sheet



## Product features

### Fry-top griddle plate 65x48 gas combined counter top

<b>Model</b>	<b>SAP Code</b>	00000993
--------------	-----------------	----------



- Top type: Combined
- Griddle dimensions [mm x mm]: 650 x 480
- Griddle thickness [mm]: 10.00
- Container for liquid fat: Yes
- Independent heating zones: Separate control for each heating zone
- Maximum device temperature [°C]: 300
- Surface finish: sandblasted surface without coating
- Removable rim: No
- Ignition: Piezo

<b>SAP Code</b>	00000993	<b>Power gas [kW]</b>	8.000
<b>Net Width [mm]</b>	658	<b>Type of gas</b>	Propane butane, natural gas
<b>Net Depth [mm]</b>	0	<b>Griddle dimensions [mm x mm]</b>	650 x 480
<b>Net Height [mm]</b>	285	<b>Top type</b>	Combined
<b>Net Weight [kg]</b>	45.00		

# Technical data sheet



Technical drawing

## Fry-top griddle plate 65x48 gas combined counter top

<b>Model</b>	<b>SAP Code</b>	00000993
--------------	-----------------	----------

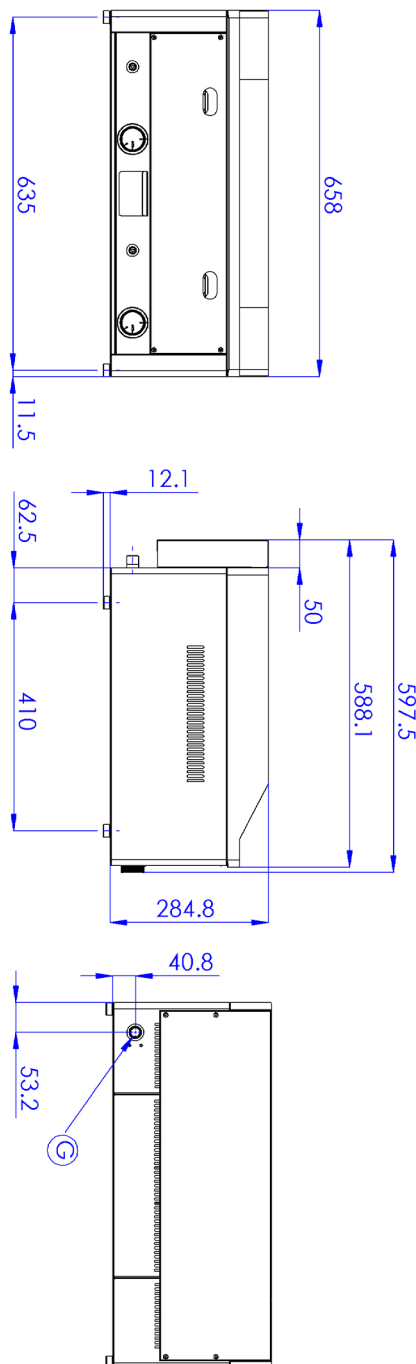

# Technical data sheet



## Product benefits

### Fry-top griddle plate 65x48 gas combined counter top

Model

SAP Code

00000993

1

#### Safety element – thermocouple

safe service for staff  
there is no unnecessary gas leakage  
long life

- savings on service interventions
- easier and faster operation

2

#### All-stainless design

long life  
resistance of AISI 304 stainless steel material  
the material does not cut

- savings on service interventions
- easy cleaning and maintenance of equipment

3

#### Degree of protection of the control elements IPX4

maintenance-free system  
resistance to splash water  
long life

- savings on service interventions
- easy cleaning and maintenance of equipment

4

#### Outlet for waste liquids

ensures that oil drips into the socket

- easy maintenance
- easy cleaning

5

#### High non-removable hem

better hygienic conditions  
preventing grease from splashing onto ancillary equipment

- easy maintenance
- easy cleaning

6

#### Combined plate made of sandblasted steel

good heat transfer  
enables preparation on smooth or grooved plates

- time-saving in food preparation
- easy preparation of different types of dishes

7

#### Cooking unit for use on a table or on a base

variable use  
the possibility of placement in smaller spaces

- easy handling
- cost savings on substructure

# Technical data sheet



## Technical parameters

### Fry-top griddle plate 65x48 gas combined counter top

**Model**

**SAP Code**

00000993

**1. SAP Code:**

00000993

**2. Net Width [mm]:**

658

**3. Net Depth [mm]:**

0

**4. Net Height [mm]:**

285

**5. Net Weight [kg]:**

45.00

**6. Gross Width [mm]:**

640

**7. Gross depth [mm]:**

725

**8. Gross Height [mm]:**

410

**9. Gross Weight [kg]:**

50.00

**10. Device type:**

Gas unit

**11. Construction type of device:**

Table top

**12. Power gas [kW]:**

8.000

**13. Ignition:**

Piezo

**14. Type of gas:**

Propane butane, natural gas

**15. Protection of controls:**

IPX4

**16. Material:**

AISI 430

**17. Surface finish:**

sandblasted surface without coating

**18. Maximum device temperature [°C]:**

300

**19. Minimum device temperature [°C]:**

50

**20. Adjustable feet:**

Yes

**21. Griddle dimensions [mm x mm]:**

650 x 480

**22. Griddle thickness [mm]:**

10.00

**23. Container for liquid fat:**

Yes

**24. Independent heating zones:**

Separate control for each heating zone

**25. Removable rim:**

No

**26. Uniform heating:**

Yes

**27. Top type:**

Combinated